



VICTORY SALES ENGINEERING CO.
10F-4, No. 33 Sec. 1 Minshen Rd. Banqiao City,
Taipei County, Taiwan, R.O.C.
TEL: 886-2-2950 0123
FAX: 886-2-2950 0101
http// : www.v-electronics.com

承認書

SPECIFICATION FOR APPROVAL
Issue Date: Jan 31 2011

客戶(CUSTOMER): 升力科技有限公司

產品(PRODUCT): 5mm Round Bi-Color LED

型號(MODEL): VT 5J47

料號(CODE): 1320R0200043000

日期 (ISSUE DATE): Jan 31 2011

				
--	--	--	--	---------------------------------------------------------------------------------------

威質達有限公司

5mm Bi-Color LED Common Cathode

VT 5J47

Description

The VT 5J47 is 5mm Bi-Color LED Lamp. The chip material used in RED & GREEN emitting is high efficiency GaP & GaAsP/GaP with brilliant light output. It has high reliability lead based package and available in full selection of colors, high intensity under low current condition

Other selection included Common Cathode or Common Anode and lead pitch is 2.54mm.

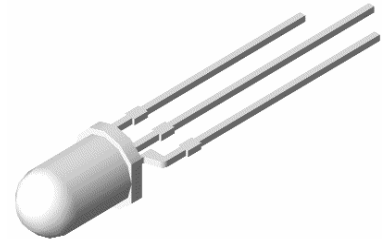



Applications

- TV Set
- Monitor
- Telephone
- Computer



Electronic Optical Characteristics (at 20mA):

Part Number	Emitted Color	λ (nm)		Iv(mcd)		VF(Volt)		View Angle	Lens
		λ d	λ p	Min	Typ.	Typ.	Max.		
VT 5J47	Yellow-green 	571	570	4.5	10	2.0	2.4	60	White Diffuse
	Red 	625	635	7.1	12	2.0	2.4		

Absolute Maximum Ratings (at Ta=25°C)

Color	P _D (mW)	I _{FP} (mA)	I _F (mA)	T _{sol} (°C)	I _R (uA) @VR=5V	T _{opr} (°C)	T _{stg} (°C)
Yellow-green	60	100	30	260+/-5 for 5 sec	10	-40~+85	-40~+90
Red	60	100	30		10	-40~+85	-40~+90

Note: Please take note the Absolute Maximum Rating values. Any operation beyond the specify ratings in this table will result degradation of LED life- span and may cause LED to fail.

* I_{FP}: Peak Forward Current under 1/10 duty, 1KHz condition

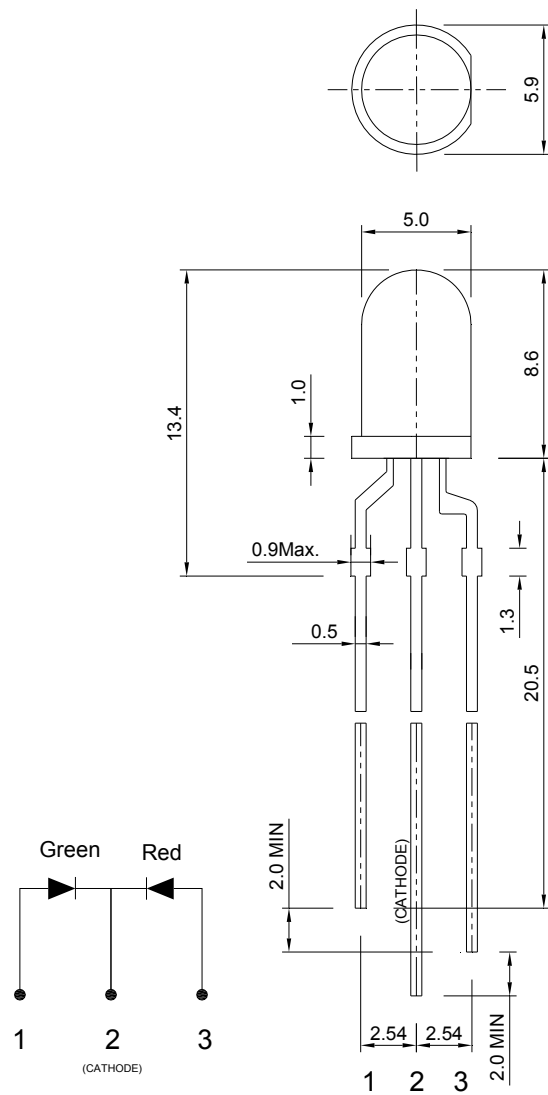
Package Dimension:

unit: mm

Notes:

1. All dimensions are millimeters.
2. Tolerance is ± 0.2 mm unless otherwise specified.
3. Specifications are subject to change without notice.

Test Report

No. : CE/2009/60677A Date : 2009/07/17

Page : 1 of 6

VICTORY ELECTRONICS CO., LTD.
10F-4, NO. 33, SEC. 1, MINSHENG ROAD, BANQIAO CITY, TAIPEI
COUNTY 22069, TAIWAN, R. O. C.



The following sample(s) was/were submitted and identified by/on behalf of the client as :

Sample Description : DIP ARRAY LED
Style/Item No. : VT XXXX / VF XXXX / VA XXXX
Sample Receiving Date : 2009/06/02
Testing Period : 2009/06/02 TO 2009/06/08

=====
Test Requested : In accordance with the RoHS Directive 2002/95/EC, and its amendment directives.
Test Method : With reference to IEC 62321: 2008 Procedures for the Determination of Levels of Regulated Substances in Electrotechnical Products.
(1) Determination of Cadmium by ICP-AES.
(2) Determination of Lead by ICP-AES.
(3) Determination of Mercury by ICP-AES.
(4) Determination of Hexavalent Chromium by UV/Vis Spectrometry.
(5) Determination of Hexavalent Chromium by Spot test / boiling water extraction Method.
(6) Determination of PBB and PBDE by GC/MS.
Test Result(s) : Please refer to next page(s).

Chenyu Kung / Operation Manager
Signed for and on behalf of
SGS TAIWAN LTD.
Chemical Laboratory – Taipei

Unless otherwise stated the results shown in this test report refer only to the sample(s) tested. This test report cannot be reproduced, except in full, without prior written permission of the Company. 除非另有說明，此報告結果僅對測試之樣品負責。本報告未經本公司書面許可，不可部分複製。

This Test Report is issued by the Company under its General Conditions of Service printed overleaf or available on request and accessible at http://www.sgs.com/terms_and_conditions.htm. Attention is drawn to the limitation of liability, indemnification and jurisdiction issues defined therein. Any holder of this Test Report is advised that information contained hereon reflects the Company's findings at the time of its intervention only and within the limits of Client's instructions, if any. The Company's sole responsibility is to its Client and this document does not exonerate parties to a transaction from exercising all their rights and obligations under the transaction documents. Any unauthorized alteration, forgery or falsification of the content or appearance of this document is unlawful and offenders may be prosecuted to the fullest extent of the law.

Test Report

No. : CE/2009/60677A Date : 2009/07/17

Page : 2 of 6

VICTORY ELECTRONICS CO., LTD.
10F-4, NO. 33, SEC. 1, MINSHENG ROAD, BANQIAO CITY, TAIPEI
COUNTY 22069, TAIWAN, R. O. C.



Test results by chemical method (Unit: mg/kg)

Test Item (s):	Method (Refer to)	Result		MDL
		No.1	No.2	
Cadmium (Cd)	(1)	n.d.	n.d.	2
Lead (Pb)	(2)	27	n.d.	2
Mercury (Hg)	(3)	n.d.	n.d.	2
Hexavalent Chromium Cr(VI) by alkaline extraction	(4)	n.d.	---	2
Hexavalent Chromium Cr(VI) by Spot test / boiling water extraction	(5)	---	Negative	See Note 4
Sum of PBBs	(6)	n.d.	n.d.	-
Monobromobiphenyl		n.d.	n.d.	5
Dibromobiphenyl		n.d.	n.d.	5
Tribromobiphenyl		n.d.	n.d.	5
Tetrabromobiphenyl		n.d.	n.d.	5
Pentabromobiphenyl		n.d.	n.d.	5
Hexabromobiphenyl		n.d.	n.d.	5
Heptabromobiphenyl		n.d.	n.d.	5
Octabromobiphenyl		n.d.	n.d.	5
Nonabromobiphenyl		n.d.	n.d.	5
Decabromobiphenyl		n.d.	n.d.	5
Sum of PBDEs		n.d.	n.d.	-
Monobromodiphenyl ether		n.d.	n.d.	5
Dibromodiphenyl ether		n.d.	n.d.	5
Tribromodiphenyl ether		n.d.	n.d.	5
Tetrabromodiphenyl ether		n.d.	n.d.	5
Pentabromodiphenyl ether		n.d.	n.d.	5
Hexabromodiphenyl ether		n.d.	n.d.	5
Heptabromodiphenyl ether		n.d.	n.d.	5
Octabromodiphenyl ether		n.d.	n.d.	5
Nonabromodiphenyl ether	n.d.	n.d.	5	
Decabromodiphenyl ether	n.d.	n.d.	5	

TEST PART DESCRIPTION:

NO.1 : MIXED TRANSPARENT, TRANSLUCENT, TRANSPARENT-RED, TRANSPARENT-YELLOW, TRANSPARENT-BLUE, TRANSPARENT-GREEN, GREEN BODY

NO.2 : SILVER COLORED METAL PIN (INCLUDING THE PLATING LAYER)

Unless otherwise stated the results shown in this test report refer only to the sample(s) tested. This test report cannot be reproduced, except in full, without prior written permission of the Company. 除非另有說明，此報告結果僅對測試之樣品負責。本報告未經本公司書面許可，不可部分複製。

This Test Report is issued by the Company under its General Conditions of Service printed overleaf or available on request and accessible at http://www.sgs.com/terms_and_conditions.htm. Attention is drawn to the limitation of liability, indemnification and jurisdiction issues defined therein. Any holder of this Test Report is advised that information contained hereon reflects the Company's findings at the time of its intervention only and within the limits of Client's instructions, if any. The Company's sole responsibility is to its Client and this document does not exonerate parties to a transaction from exercising all their rights and obligations under the transaction documents. Any unauthorized alteration, forgery or falsification of the content or appearance of this document is unlawful and offenders may be prosecuted to the fullest extent of the law.

Test Report

No. : CE/2009/60677A Date : 2009/07/17

Page : 3 of 6

VICTORY ELECTRONICS CO., LTD.
10F-4, NO. 33, SEC. 1, MINSHENG ROAD, BANQIAO CITY, TAIPEI
COUNTY 22069, TAIWAN, R. O. C.



Note : 1. mg/kg = ppm ; 0.1wt% = 1000ppm

2. n.d. = Not Detected

3. MDL = Method Detection Limit

4. Spot-test:

Negative = Absence of Cr(VI) coating / surface layer,

Positive = Presence of Cr(VI) coating / surface layer;

(The tested sample should be further verified by boiling-water-extraction method if the spot test result cannot be confirmed.)

Boiling-water-extraction:

Negative = Absence of Cr(VI) coating / surface layer.

Positive = Presence of Cr(VI) coating / surface layer;

the detected concentration in boiling-water-extraction solution is equal or greater than 0.02 mg/kg with 50 cm² sample surface area.

5. "-" = Not Regulated

6. "---" = Not Conducted

7. The sample(s) was/were analyzed on behalf of the applicant as mixing sample in one testing.
The above result(s) was/were only given as the informality value.

Unless otherwise stated the results shown in this test report refer only to the sample(s) tested. This test report cannot be reproduced, except in full, without prior written permission of the Company. 除非另有說明，此報告結果僅對測試之樣品負責。本報告未經本公司書面許可，不可部分複製。

This Test Report is issued by the Company under its General Conditions of Service printed overleaf or available on request and accessible at http://www.sgs.com/terms_and_conditions.htm. Attention is drawn to the limitation of liability, indemnification and jurisdiction issues defined therein. Any holder of this Test Report is advised that information contained hereon reflects the Company's findings at the time of its intervention only and within the limits of Client's instructions, if any. The Company's sole responsibility is to its Client and this document does not exonerate parties to a transaction from exercising all their rights and obligations under the transaction documents. Any unauthorized alteration, forgery or falsification of the content or appearance of this document is unlawful and offenders may be prosecuted to the fullest extent of the law.

Test Report

No. : CE/2009/60677A Date : 2009/07/17

Page : 4 of 6

VICTORY ELECTRONICS CO., LTD.
10F-4, NO. 33, SEC. 1, MINSHENG ROAD, BANQIAO CITY, TAIPEI
COUNTY 22069, TAIWAN, R. O. C.



- 1) These samples were dissolved totally by pre-conditioning method according to below flow chart.
(Cr⁶⁺ test method excluded)
- 2) Name of the person who made measurement: Climbgreat Yang
- 3) Name of the person in charge of measurement: Troy Chang

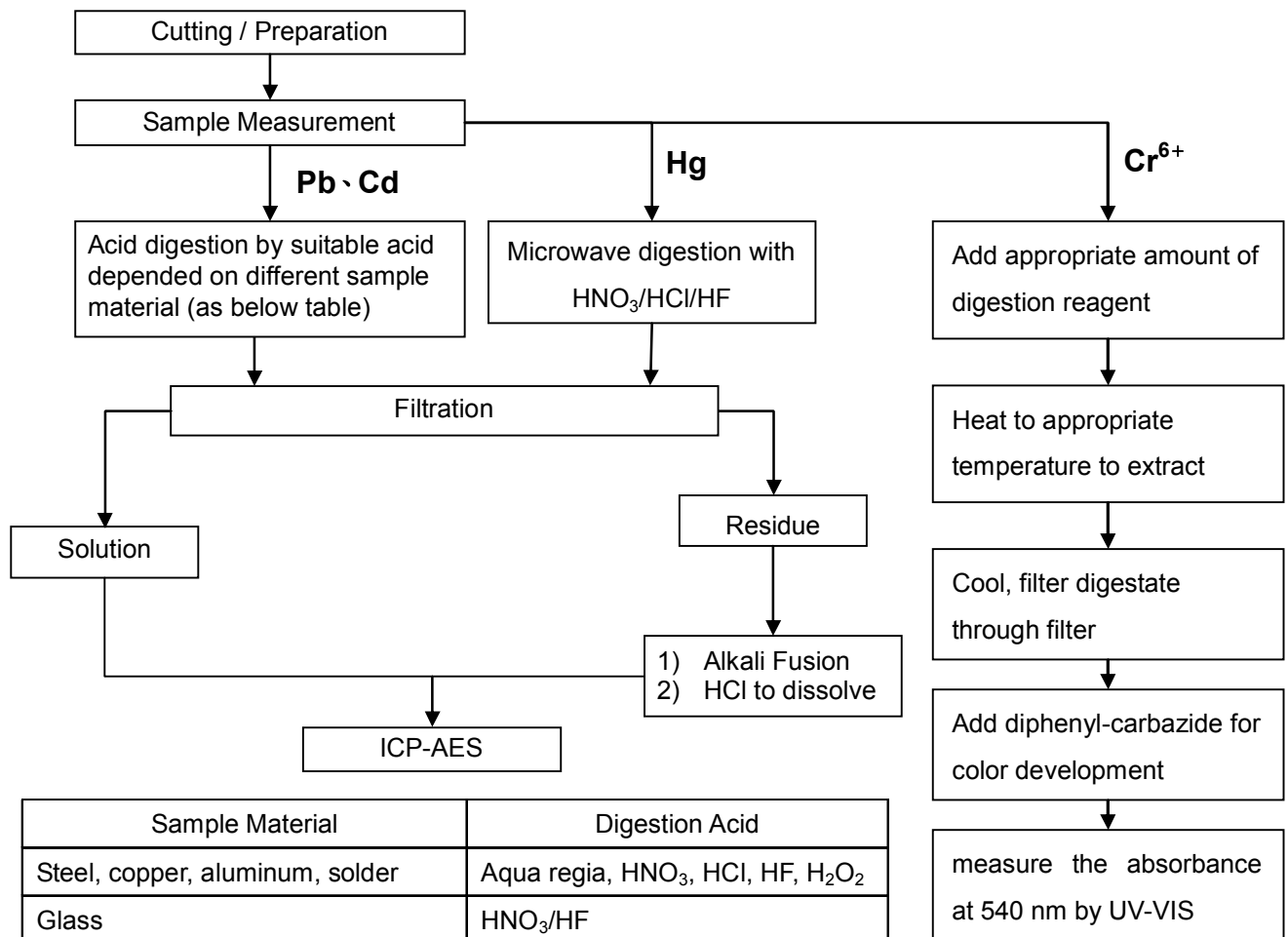

Sample Material	Digestion Acid
Steel, copper, aluminum, solder	Aqua regia, HNO ₃ , HCl, HF, H ₂ O ₂
Glass	HNO ₃ /HF
Gold, platinum, palladium, ceramic	Aqua regia
Silver	HNO ₃
Plastic	H ₂ SO ₄ , H ₂ O ₂ , HNO ₃ , HCl
Others	Any acid to total digestion

Unless otherwise stated the results shown in this test report refer only to the sample(s) tested. This test report cannot be reproduced, except in full, without prior written permission of the Company. 除非另有說明，此報告結果僅對測試之樣品負責。本報告未經本公司書面許可，不可部分複製。

This Test Report is issued by the Company under its General Conditions of Service printed overleaf or available on request and accessible at http://www.sgs.com/terms_and_conditions.htm. Attention is drawn to the limitation of liability, indemnification and jurisdiction issues defined therein. Any holder of this Test Report is advised that information contained hereon reflects the Company's findings at the time of its intervention only and within the limits of Client's instructions, if any. The Company's sole responsibility is to its Client and this document does not exonerate parties to a transaction from exercising all their rights and obligations under the transaction documents. Any unauthorized alteration, forgery or falsification of the content or appearance of this document is unlawful and offenders may be prosecuted to the fullest extent of the law.

Test Report

No. : CE/2009/60677A Date : 2009/07/17

Page : 5 of 6

VICTORY ELECTRONICS CO., LTD.
 10F-4, NO. 33, SEC. 1, MINSHENG ROAD, BANQIAO CITY, TAIPEI
 COUNTY 22069, TAIWAN, R. O. C.



PBB/PBDE analytical FLOW CHART

- 1) Name of the person who made measurement: Roman Wong
- 2) Name of the person in charge of measurement: Shinjyh Chen

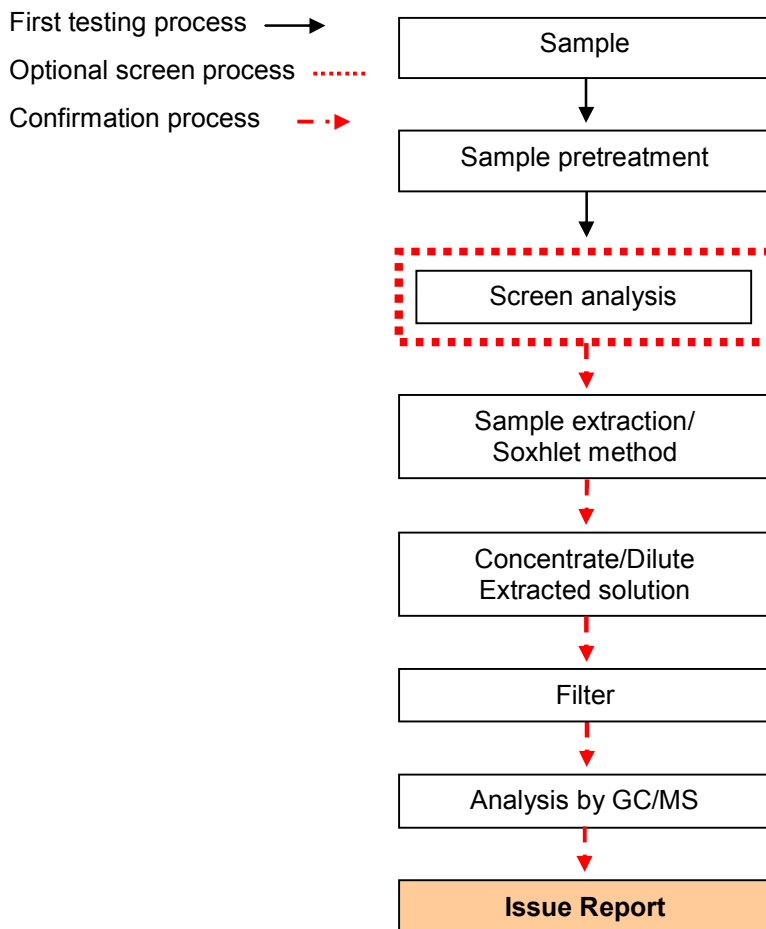

Unless otherwise stated the results shown in this test report refer only to the sample(s) tested. This test report cannot be reproduced, except in full, without prior written permission of the Company. 除非另有說明，此報告結果僅對測試之樣品負責。本報告未經本公司書面許可，不可部分複製。

This Test Report is issued by the Company under its General Conditions of Service printed overleaf or available on request and accessible at http://www.sgs.com/terms_and_conditions.htm. Attention is drawn to the limitation of liability, indemnification and jurisdiction issues defined therein. Any holder of this Test Report is advised that information contained hereon reflects the Company's findings at the time of its intervention only and within the limits of Client's instructions, if any. The Company's sole responsibility is to its Client and this document does not exonerate parties to a transaction from exercising all their rights and obligations under the transaction documents. Any unauthorized alteration, forgery or falsification of the content or appearance of this document is unlawful and offenders may be prosecuted to the fullest extent of the law.

Test Report

No. : CE/2009/60677A Date : 2009/07/17

Page : 6 of 6

VICTORY ELECTRONICS CO., LTD.
 10F-4, NO. 33, SEC. 1, MINSHENG ROAD, BANQIAO CITY, TAIPEI
 COUNTY 22069, TAIWAN, R. O. C.



NO.1



NO.2



** End of Report **

Unless otherwise stated the results shown in this test report refer only to the sample(s) tested. This test report cannot be reproduced, except in full, without prior written permission of the Company. 除非另有說明，此報告結果僅對測試之樣品負責。本報告未經本公司書面許可，不可部分複製。

This Test Report is issued by the Company under its General Conditions of Service printed overleaf or available on request and accessible at http://www.sgs.com/terms_and_conditions.htm. Attention is drawn to the limitation of liability, indemnification and jurisdiction issues defined therein. Any holder of this Test Report is advised that information contained hereon reflects the Company's findings at the time of its intervention only and within the limits of Client's instructions, if any. The Company's sole responsibility is to its Client and this document does not exonerate parties to a transaction from exercising all their rights and obligations under the transaction documents. Any unauthorized alteration, forgery or falsification of the content or appearance of this document is unlawful and offenders may be prosecuted to the fullest extent of the law.